

VIPEC V44 & V88

ONE DUAL CHANNEL BOSCH MODULE, AND WASTED SPARK

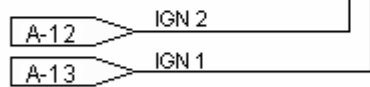

Software Settings
 Select Rising , and set dwell time to suit the coil type in the Ignition Dwell Table
CAUTION: Incorrect dwell time will damage ignition coils or modules

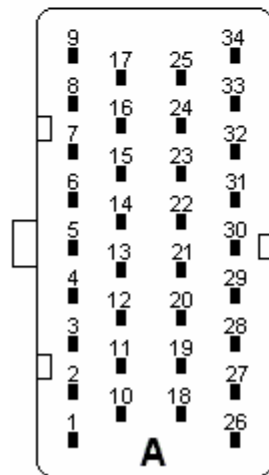
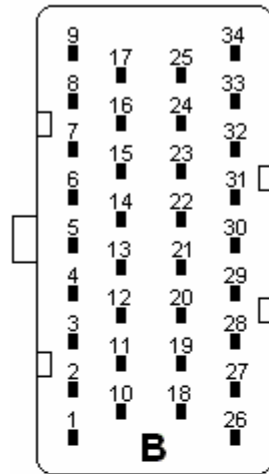
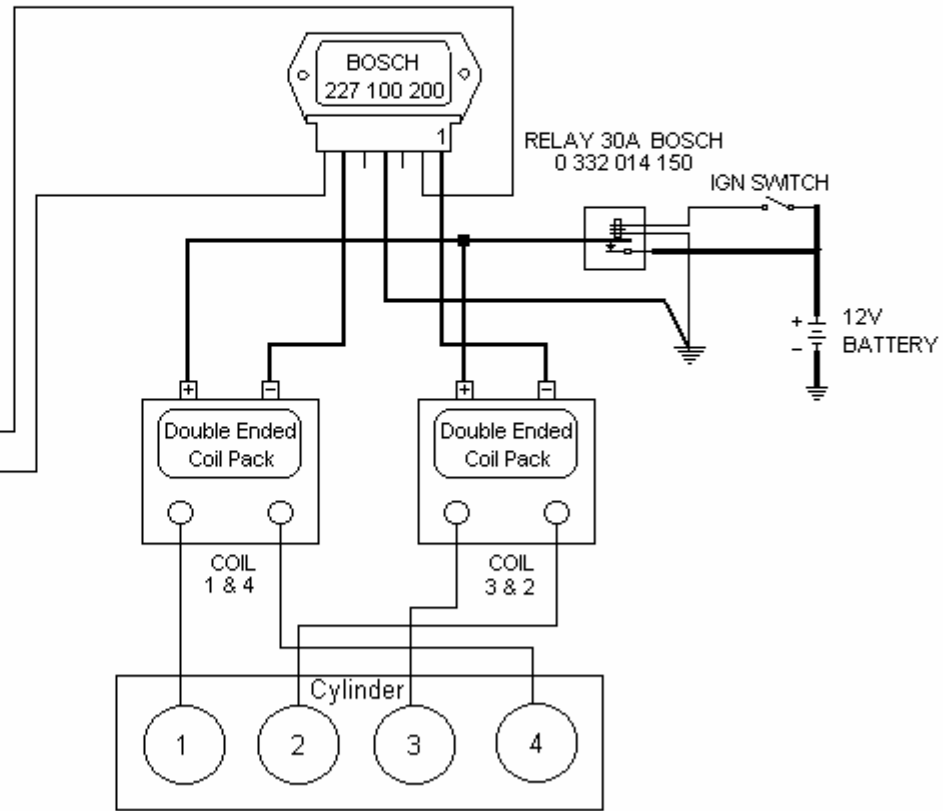

Four Cyl engine with 1,3,4,2 firing order

Wires donated — 1.8 - 1.4 mm Dia. Conductor 20 - 14 AWG.
 Wires donated — 3.0 - 4.0 mm Dia. Conductor 1.5 - 2.5 SQ mm