

VIPEC V88

VIPEC V88 DFI SETUP USING 8 X COILS AND BOSCH 200 IGNITION MODULES

Software Settings
 Select Rising , and set dwell time to suit the coil type in the Ignition Dwell Table
 CAUTION: Incorrect dwell time will damage ignition coils or modules

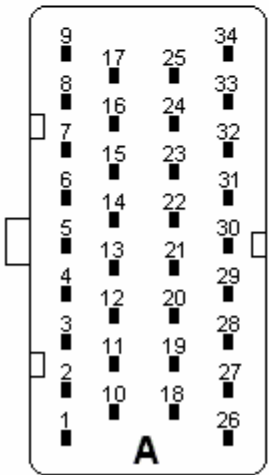
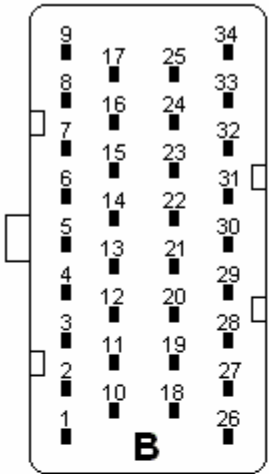

- B-1 IGN 8
- B-2 IGN 7
- B-3 IGN 6
- B-4 IGN 5
- A-10 IGN 4
- A-11 IGN 3
- A-12 IGN 2
- A-13 IGN 1

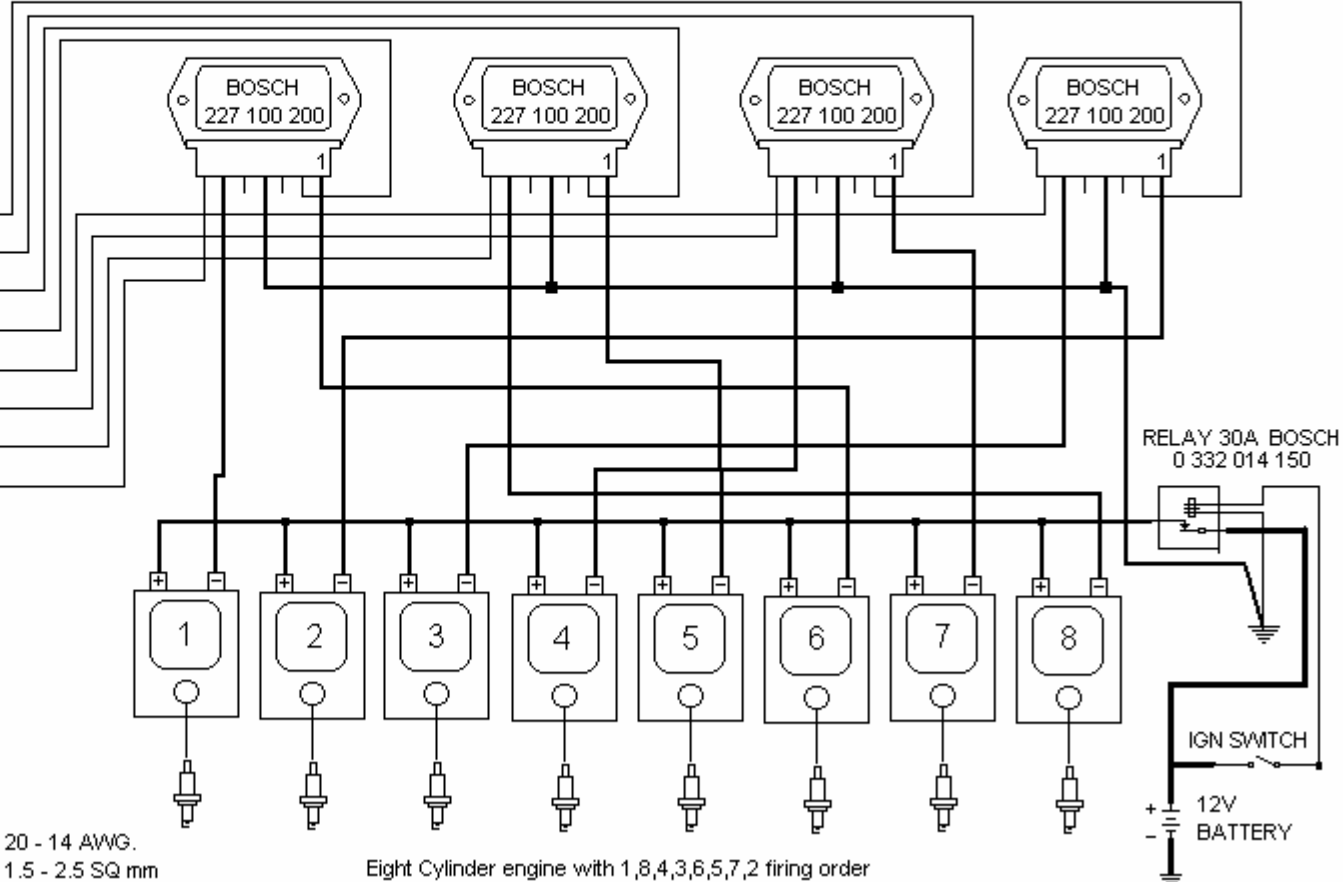

Wires donated — 1.8 - 1.4 mm Dia. Conductor 20 - 14 AWG.
 Wires donated — 3.0 - 4.0 mm Dia. Conductor 1.5 - 2.5 SQ mm

Eight Cylinder engine with 1,8,4,3,6,5,7,2 firing order